

# AD20-23Sxx Series

AC-DC Converter | 20W | Compact size | DIP | 4000VAC | 85~305VAC



## Features

- Universal Input: 85~305VAC / 100~430VDC
- Operating temperature range: -40°C ~ +85°C
- Isolation voltage: 4000VAC
- High efficiency up to: 87%(Typ.)
- Overvoltage category III (OVC III)
- EMI Class B without additional components
- Designed to meet IEC/EN/UL62368, EN60335, EN61558

## Product description



AD20-23Sxx series is a 20W miniature AC DC module-type power supply provided by BETTPOWER. This series features the universal input voltage range of 85-305Vac, low power consumption, high efficiency, high reliability, and reinforced isolation. The entire series is compliance with BS EN/EN55032 Class B without the need of any additional components. The EMC and safety specification design complies with IEC/EN61000-4, CISPR32/EN55032, IEC/EN/UL62368, EN60335, IEC/EN/BS EN61558. These power supply modules are widely used in industries, power generation, household appliances, instrumentation, communication, and civil applications.

## Selection Guide

Certification	Part No.	Input Voltage (VAC)	Out Power (W)	Out Voltage (VDC)	Out Current Max.(mA)	Full Load Efficiency %(230VAC, Typ.)	Capacitive Load Max.( $\mu$ F)
EN/UL pending	AD20-23S03	85~305	14.85	3.3	4500	81	8000
	AD20-23S05	85~305	20	5	4000	85	8000
	AD20-23S09	85~305	20	9	2200	84	5400
	AD20-23S12	85~305	20	12	1670	85	4000
	AD20-23S15	85~305	20	15	1330	86	3000
	AD20-23S18	85~305	20	18	1112	86	3000
	AD20-23S24	85~305	20	24	830	87	1000

Note:

1. All the above data were tested within the parameter range of typical application circuits;
2. The product images are for reference only. Please refer to the actual product for details;
3. Adding "T" to the product model suffix indicates an extension for chassis mount packaging, while adding "Din" to the suffix indicates an extension for Din-rail mount packaging.

## Input Specifications

Item	Operating Conditions	Min.	Typ.	Max.	Unit
Input Voltage Range	AC input	85	--	305	VAC
	DC input	100	--	430	VDC
Input Current	115VAC	--	--	0.5	A
	230VAC	--	--	0.3	A
Inrush Current	115VAC	--	30	--	A
	230VAC	--	60	--	A
Input Frequency		47	--	63	Hz
Recommended External Input Fuse		3.15A/300V, slow-blow, required			
Leakage Current	230VAC/50Hz	0.1mA RMS Max.			
Hot Plug		Unavailable			

## Output Specifications

Item	Operating Conditions	Min.	Typ.	Max.	Unit
Output Voltage Accuracy	10% ~ 100% load	--	±2	--	%
Line Regulation	Full load	--	±0.5	--	%
Load Regulation	0 ~ 100% load	--	±1.0	--	%
Ripple & Noise*	20MHz bandwidth (peak-to-peak value), 5% ~ 100% load	--	100	150	mV
Temperature Coefficient		--	±0.02	--	%/°C
Stand-by Power Consumption	230VAC	--	0.1	--	W
Min. Load		0	--	--	%
Over-current Protection		110	--	--	%Io
Short Circuit Protection		Continuous, Self-Recovery			
Hold-up Time	230VAC	--	50	--	ms

Note: Ripple & noise are measured at 20MHz of bandwidth with a 10uF electrolytic capacitor and a 1uF ceramic capacitor connected inparallel at the output.

## General Specifications

Item	Operating Conditions			Min.	Typ.	Max.	Unit
Isolation Voltage	Input-output, test time 1 minute, leakage current less than 5mA			4000	--	--	VAC
Insulation Resistance	Input-output, insulated voltage 500VDC			100	--	--	MΩ
Power Derating	-40°C ~ -25°C	Input voltage	85~165VAC	2.0	--	--	%°C
		Output voltage	3.3/5/9V	2.8	--	--	%°C
	+55°C ~ +85°C			12/15/18/24V	2.33	--	--

	85VAC ~ 100VAC	2.0	--	--	%/VAC
	277VAC ~ 305VAC	0.7	--	--	%/VAC
Operating Temperature		-40	--	85	°C
Storage Temperature		-40	--	85	°C
Storage Humidity	Non-condensing	--	--	95	%RH
Soldering Profile	Wave-soldering	260 ± 5°C; time: 5 - 10s			
	Munual soldering	360 ± 10°C; time: 3 - 5s			
Safety Standard	Product design conforms to IEC/EN/BS EN62368-1, IEC/EN/BS EN61558-1/-2-16, EN60335-1, UL62368-1				
Safety Class	CLASS II				
MTBF	MIL-HDBK-217F@25°C	>1,500,000h			

## Mechanical Specifications

Case Material	Black plastic, flame-retardant and heat-resistant (UL94V-0)
Package Dimensions	52.40 * 27.20 * 24.00mm
Weight	50.5g(Typ.)
Cooling Method	Free air convection

## Electromagnetic Compatibility (EMC)

EMI	CE	CISPR32/EN55032 CLASS B CISPR11/EN55011 CLASS B EN55014-1	
	RE	CISPR32/EN55032 CLASS B CISPR11/EN55011 CLASS B EN55014-1	
EMS	RS	IEC/EN61000-4-3 10V/m	perf. Criteria A
		EN55014-2	perf. Criteria A
	EFT	IEC/EN61000-4-4 ±2KV (EMC Solutions - Recommended Circuit(2-1))	perf. Criteria B
		IEC/EN61000-4-4 ±4KV (EMC Solutions - Recommended Circuit(2-2))	perf. Criteria A
		EN55014-2	perf. Criteria B
	Surge	IEC/EN61000-4-5 line to line ±1KV	perf. Criteria B
		IEC/EN61000-4-5 line to line ±2KV(EMC Solutions - Recommended Circuit(2-2))	perf. Criteria B
		IEC/EN61000-4-5 line to line ±2KV/line to PE ±4KV(EMC Solutions - Recommended Circuit(2-2))	perf. Criteria A
EN55014-2		perf. Criteria B	
CS	IEC/EN61000-4-6 10Vr.m.s	perf. Criteria A	
	EN55014-2	perf. Criteria A	
ESD	IEC/EN61000-4-2 Contact ±6KV / Air ±8KV	perf. Criteria B	

## Product Characteristic Curve

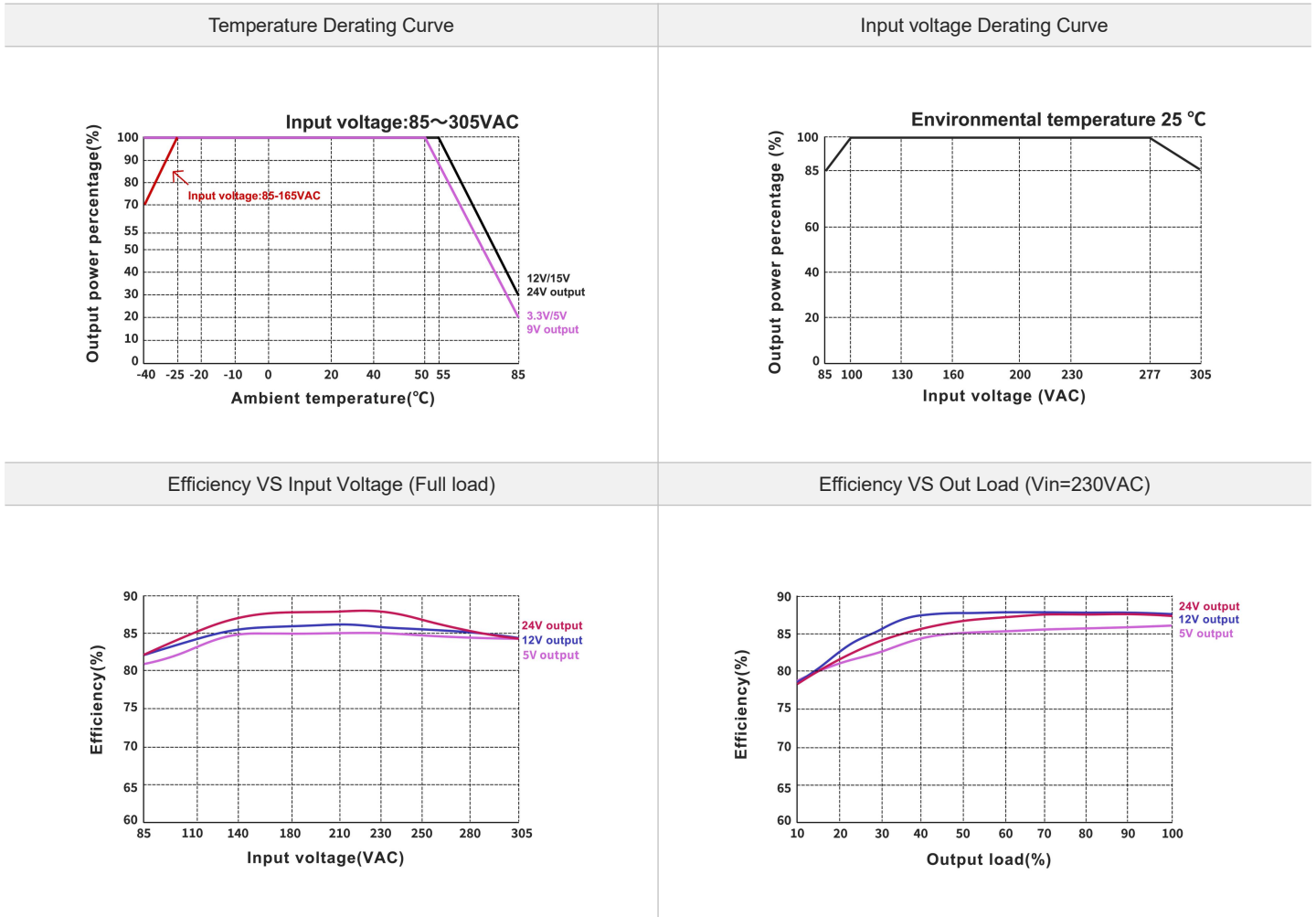

Note:

1. For input voltages of 85-100VAC/277-305VAC, voltage derating should be carried out on the basis of temperature derating.
2. This product is suitable for use in a natural wind-cooled environment.

## Design Reference - Application circuit

Application circuit(Figure 1)

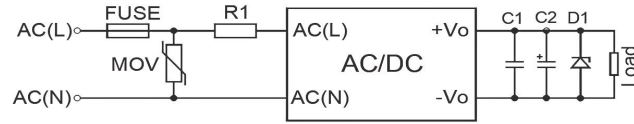

Reference Table for Selection of Peripheral Devices

Part No.	FUSE	MOV	R1	C1	C2	D1
AD20-23S03	3.15A/300VAC Slow-blow Required	14D561K	3Ω/3W Wire-wound resistor Required	1uF/16V	330uF/16V	See Note 2
AD20-23S05				1uF/16V	330uF/16V	
AD20-23S09				1uF/25V	220uF/25V	
AD20-23S12				1uF/25V	220uF/25V	
AD20-23S15				1uF/25V	220uF/25V	
AD20-23S18				1uF/50V	100uF/35V	
AD20-23S24				1uF/50V	100uF/35V	

Note:

1. FUSE and MOV can be selected based on actual needs.
2. D1 is a TVS transistor that can protect the downstream circuit in case of module abnormalities. It is recommended to choose a model that is 1.2 times the output voltage.

Design Reference - EMC Solutions - Recommended Circuits

EMC Solutions - Recommended Circuits(Figure 2-1)

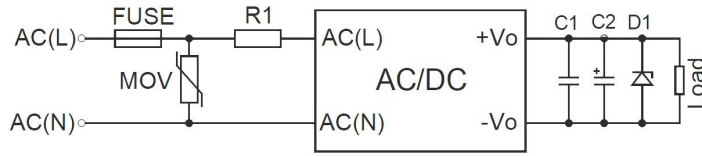

EMC Solutions - Recommended Circuits(Figure 2-2)

(When the output of the product needs to be connected to PE or connected to PE through Y capacitor,Recommended)

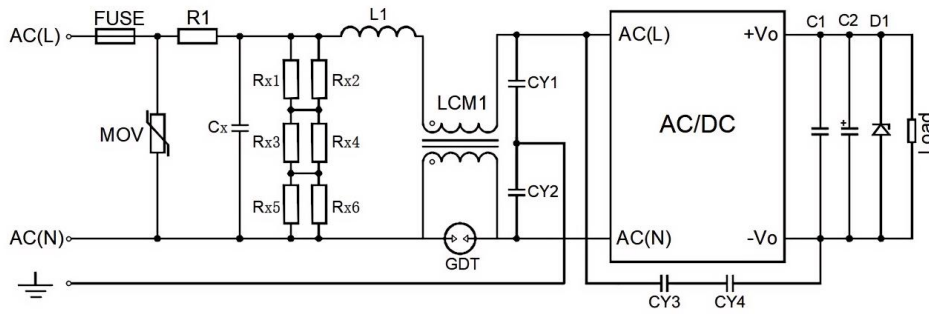

Recommended parameter values for EMC solution circuits	Model	Recommended value
	FUSE	3.15A/300VAC, Slow-blow, Required
	MOV	14D561K
	R1	6.8Ω/5W(Wire-wound resistor, Required)
	Cx	0.33uF/305VAC
	L1	1.2mH/0.5A
	CY1,CY2	2.2nF/400VAC
	CY3,CY4	2.2nF/400VAC
	GDT	300V/1KA
	LCM1	20mH, Common mode inductance
	Rx1,Rx2,Rx3,Rx4	1.5MΩ/1206
	C1,C2,D1	Refer to typical circuit design and application

## Dimensions and Recommended Layout

AD20-23Sxx Dimensions and Recommended Layout

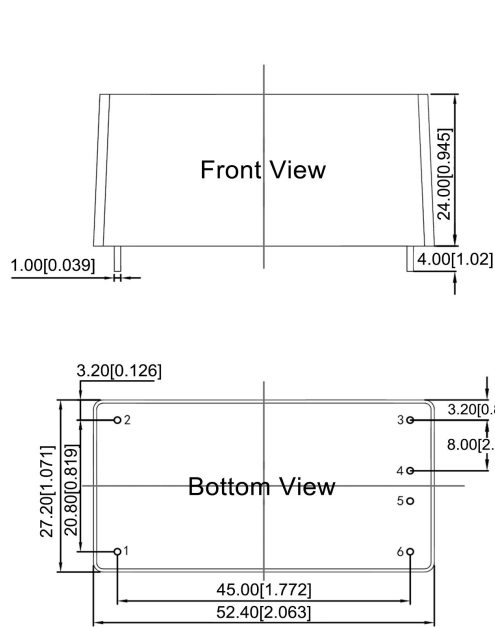

Third Angle Projection

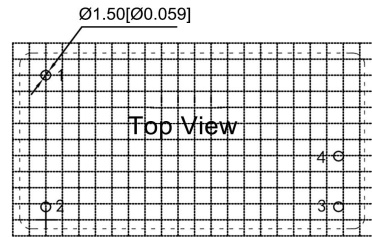

The grid distance size is 2.54mm\*2.54mm

Pin	Function
1	AC(L)
2	AC(N)
3	-Vo
4	+Vo
5,6	No Pin

Note:

Size unit: mm [inch]

Terminal diameter tolerance size:  $\pm 0.10 [\pm 0.004]$

Unmarked dimensional tolerance:  $\pm 0.50 [\pm 0.020]$

AD20-23Sxx-T wired packaging Dimensions

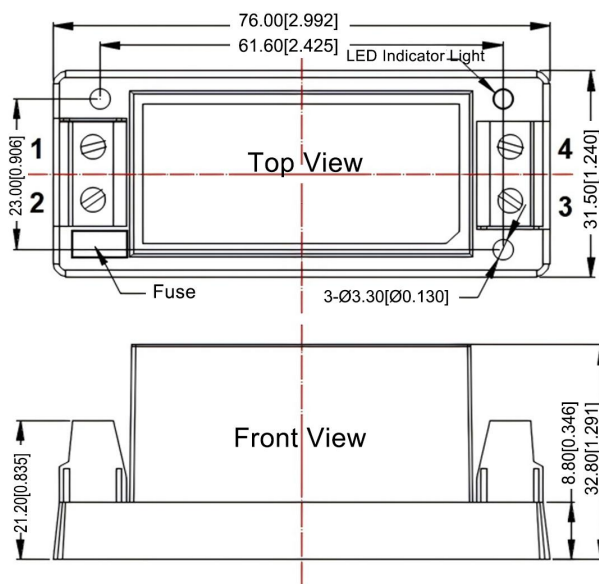

Third Angle Projection

Pin	Function
1	AC(L)
2	AC(N)
3	-Vo
4	+Vo

Note:

Size unit: mm [inch]

Wire diameter: 24-12AWG

Tightening force distance: Max0.4N · m

Unmarked tolerance:  $\pm 1.00 [\pm 0.039]$

## AD20-23Sxx-DIN rail-mounted packaging Dimensions

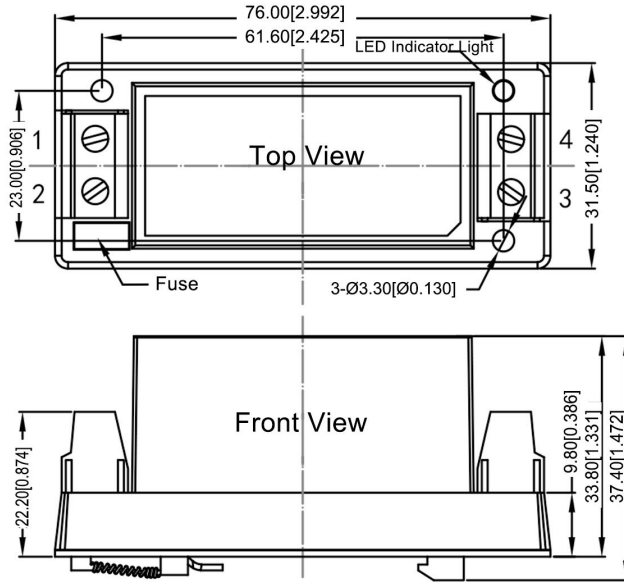

Third Angle Projection

Pin	Function
1	AC(L)
2	AC(N)
3	-Vo
4	+Vo

Note:

Size unit: mm [inch]

Wire diameter: 24-12AWG

Tightening force distance: Max0.4N · m

Rail type: TS35, rail needs to be grounded

Unmarked tolerance:  $\pm 1.00$  [ $\pm 0.039$ ]

## Packaging Information

Model series	Product quantity(pcs/tray)	Inner carton quantity(pcs/carton)	Outer carton quantity(pcs/carton)
AD20-23Sxx	35	105	210
AD20-23Sxx-T	28	56	112
AD20-23Sxx-DIN	28	56	112

The schematic diagram of pearl cotton packaging is shown below:

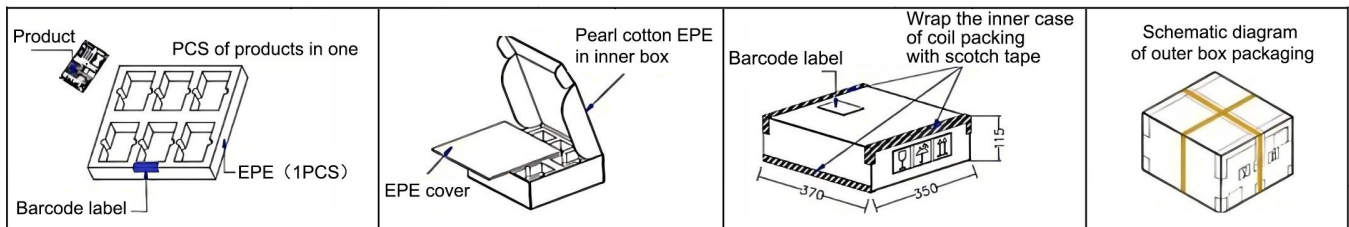

## Product precautions

1. The input voltage should not exceed the specified range value, otherwise it may cause permanent and irreparable damage;
  2. It is recommended to use at a load of over 5%. If the load is below 5%, the ripple index of the product may exceed the specifications, but it does not affect the reliability of the product;
  3. The maximum capacitive load is tested within the input voltage range and under full load conditions;
  4. Unless otherwise specified, all indicators in this manual are measured at  $T_a=25\text{ }^\circ\text{C}$ , humidity<75% RH, nominal input voltage, and output rated load;
  5. All indicator testing methods in this manual are based on our company's corporate standards;
  6. Our company can provide product customization, and specific requirements can be directly contacted by our technical personnel;
- Product specifications are subject to change without prior notice.

## Manufacturer contact information

### Bettpower Guangzhou Electronic Technology Co., Ltd.

Website: [www.bettpower.com](http://www.bettpower.com)

Telephone: +86 - 020 - 32166256

Email: [info@bettpower.com](mailto:info@bettpower.com)

Address: Room 2514-2515, Building A1, 1 Doutang Road, Huangpu District, Guangzhou, China

BETTPOWER is a registered trademark of BETTPOWER Guangzhou Electronic Technology Co., Ltd. All of its product names, models, trademarks and brands are the property of the Company.

BETTPOWER Guangzhou Electronic Technology Co., Ltd reserves all rights and the right of final interpretation.