

DF1-xxDxxLS Series

DC-DC Converter | 1W | SIP7 | Fixed voltage input, unregulated output | 3000VDC

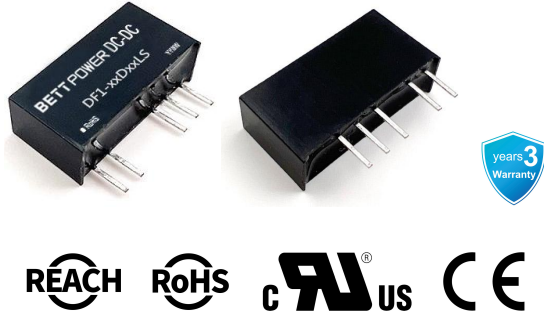

Features

- SIP7 Package
- Operating Temperature Range: -40°C ~ +105°C
- Isolation Voltage: 3000VDC
- Full Load Efficiency: up to 88% (typ.)
- Continuous Short Circuit Protection
- Designed to meet IEC/EN/BS EN/UL 62368

Product Description



The DF1-xxDxxLS series is 1W unregulated DC/DC converters that are typically used in cost sensitive general purpose power isolation and voltage matching applications. Typical applications are digital interfaces, voltage conversion in distributed powersy stems, general low-frequency analog circuits, relay drive circuits, data switching circuits etc.

Selection Guide

Certification	Part No.	Input Voltage	Output			Full Load Efficiency (%) Typ.	Capacitive Load (μF) Max.
		Nominal (Range) (VDC)	Voltage (VDC)	Current (mA) Min.	Current (mA) Max.		
EN/UL Pending	DF1-03D03LS	3.3 (2.97~3.63)	±3.3	±15	±152	78	1000
	DF1-03D05LS	3.3 (2.97~3.63)	±5	±10	±100	82	1000
	DF1-03D09LS	3.3 (2.97~3.63)	±9	±5	±56	84	470
	DF1-03D12LS	3.3 (2.97~3.63)	±12	±4	±42	84	220
	DF1-03D15LS	3.3 (2.97~3.63)	±15	±3	±34	84	220
	DF1-03D24LS	3.3 (2.97~3.63)	±24	±3	±21	84	220
	DF1-05D03LS	5 (4.5~5.5)	±3.3	±15	±152	84	1000
	DF1-05D05LS	5 (4.5~5.5)	±5	±10	±100	86	1000
	DF1-05D09LS	5 (4.5~5.5)	±9	±5	±56	86	470
	DF1-05D12LS	5 (4.5~5.5)	±12	±4	±42	88	220
	DF1-05D15LS	5 (4.5~5.5)	±15	±3	±34	88	220
	DF1-05D24LS	5 (4.5~5.5)	±24	±3	±21	88	220
	DF1-12D03LS	12 (10.8~13.2)	±3.3	±15	±152	84	1000
	DF1-12D05LS	12 (10.8~13.2)	±5	±10	±100	86	1000

Selection Guide

Certification	Part No.	Input Voltage	Output			Full Load Efficiency (%) Typ.	Capacitive Load(μF) Max.*
		Nominal(Range) (VDC)	Voltage (VDC)	Current (mA) Min.	Current (mA) Max.		
EN/UL Pending	DF1-12D09LS	12 (10.8~13.2)	±9	±5	±56	87	470
	DF1-12D12LS	12 (10.8~13.2)	±12	±4	±42	87	220
	DF1-12D15LS	12 (10.8~13.2)	±15	±3	±34	88	220
	DF1-12D24LS	12 (10.8~13.2)	±24	±3	±21	88	220
	DF1-15D03LS	15 (13.5~16.5)	±3.3	±15	±152	84	1000
	DF1-15D05LS	15 (13.5~16.5)	±5	±10	±100	86	1000
	DF1-15D09LS	15 (13.5~16.5)	±9	±5	±56	86	470
	DF1-15D12LS	15 (13.5~16.5)	±12	±4	±42	87	220
	DF1-15D15LS	15 (13.5~16.5)	±15	±3	±34	88	220
	DF1-15D24LS	15 (13.5~16.5)	±24	±3	±21	88	220
	DF1-24D03LS	24 (21.6~26.4)	±3.3	±15	±152	84	1000
	DF1-24D05LS	24 (21.6~26.4)	±5	±10	±100	87	1000
	DF1-24D09LS	24 (21.6~26.4)	±9	±5	±56	88	470
	DF1-24D12LS	24 (21.6~26.4)	±12	±4	±42	88	220
	DF1-24D15LS	24 (21.6~26.4)	±15	±3	±34	88	220
	DF1-24D24LS	24 (21.6~26.4)	±24	±3	±21	88	220

Note:

- *The capacitive load of the two outputs for positive and negative output is the same.
- The above efficiency is measured at nominal input voltage and rated output load.

Input Specifications

Item	Operating Conditions		Min.	Typ.	Max.	Unit
Input Current (Full Load/No-load)	3.3VDC Input	3.3VDC Output	--	370/10	389/15	mA
		Others	--	365/12	384/18	mA
	5VDC Input	3.3VDC Output	--	250/8	264/15	mA
		5/9VDC Output	--	238/10	250/15	mA
		12/15VDC Output	--	233/10	244/15	mA
		24VDC Output	--	229/18	234/25	mA
	12VDC Input	3.3VDC Output	--	100/7	103/15	mA
		5VDC Output	--	97/7	100/15	mA
		Others	--	94/8	96/15	mA
	15VDC Input	3.3VDC Output	--	82/6	84/15	mA
		5/9VDC Output	--	78/6	80/15	mA
		Others	--	75/6	78/15	mA
	24VDC Input	3.3VDC Output	--	50/3	51/15	mA
		Others	--	48/4	50/15	mA
Reflected Ripple Current			--	15	--	mA
Surge Voltage	3.3VDC Input		-0.7	--	5	VDC
	5VDC Input		-0.7	--	9	VDC
	12VDC Input		-0.7	--	18	VDC
	15VDC Input		-0.7	--	21	VDC
	24VDC Input		-0.7	--	30	VDC
Input Filter Type			Capacitance Filter			
Hot Plug			Unavailable			

Output Specifications

Item	Operating Conditions		Min.	Typ.	Max.	Unit
Output Voltage Accuracy			See Output Regulation Curve			
Line Regulation	Input Voltage Variation: $\pm 1\%$	3.3V	--	± 1.5	--	%
		Others	--	± 1.2	--	%
Load Regulation	10%~100% load	3.3VDC Output	--	10	--	%
		5VDC Output	--	10	--	%
		9VDC Output	--	6	--	%
		12VDC Output	--	6	--	%
		15VDC Output	--	6	--	%
		24VDC Output	--	5	--	%
Ripple & Noise	20MHz bandwidth, 100% load, using parallel line test method		--	45	100	mV
Temperature Coefficient	Full load		--	± 0.02	--	%/°C
Short Circuit Protection			Continuous, self-recovery			

Note: Ripple & noise are measured at 20MHz of bandwidth with a 10uF electrolytic capacitor and a 1uF ceramic capacitor connected inparallel at the output.

General Specifications

Item	Operating Conditions	Min.	Typ.	Max.	Unit
Isolation Voltage	Input-output, test time 1 minute, leakage current less than 1mA	3000	--	--	VDC
Insulation Resistance	Input-output, insulated voltage 500VDC	1000	--	--	MΩ
Isolation Capacitance	Input-Output,100KHz/0.1V	--	20	--	pF
Operating Temperature	Derating when operating temperature \geq 85℃ (See Temperature derating curve chart)	-40	--	105	℃
Storage Temperature		-55	--	125	℃
Case Temperature Rise	Ta=25℃, Nominal Input, Full Load	--	25	--	℃
Storage Humidity	Non-condensing	5	--	95	%RH
Soldering Profile	Wave soldering	260 \pm 5℃; Time: 5~10 seconds			
	Manual soldering	360 \pm 10℃; Time: 3~5 seconds			
Switching Frequency	Full Load, Nominal Input Voltage	--	220	--	kHz
MTBF	MIL-HDBK-217F@25℃	>3500Kh			

Mechanical Specifications

Case Material	Black flame-retardant heat-resistant plastic (UL94V-0)
Mechanical Dimensions	19.60 * 6.00 * 10.10mm
Weight	2.1g (typ.)
Cooling Method	Free air convection

Electromagnetic Compatibility (EMC)

EMI	CE	CISPR32/EN55032 CLASS B (EMC recommended circuit see Fig. 2)	
	RE	CISPR32/EN55032 CLASS B (EMC recommended circuit see Fig. 2)	
EMS	ESD	IEC/EN61000-4-2 Contact \pm 6KV, Air \pm 8KV	Perf. Criteria B

Product Characteristic Curve

Temperature Derating Curve

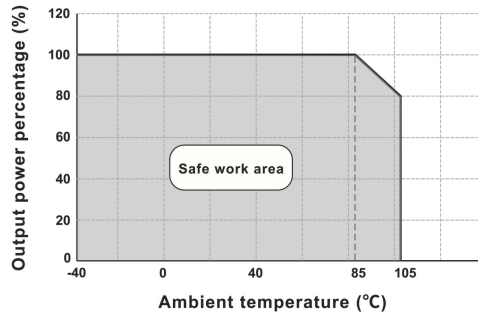

Output Regulation Curve(3.3V Output)

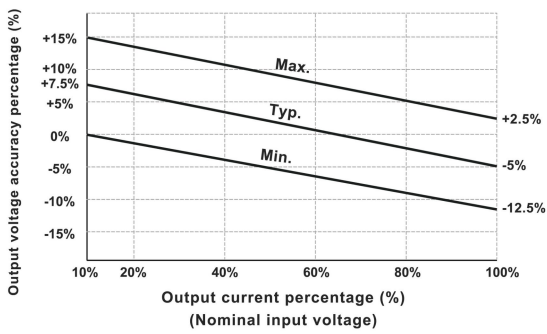

Output Regulation Curve (Others)

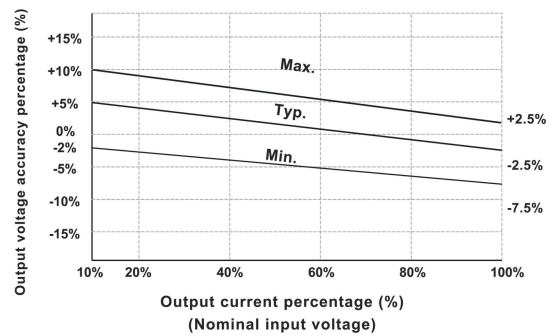

Efficiency VS Input Voltage (Full Load, DF1-05D05LS)

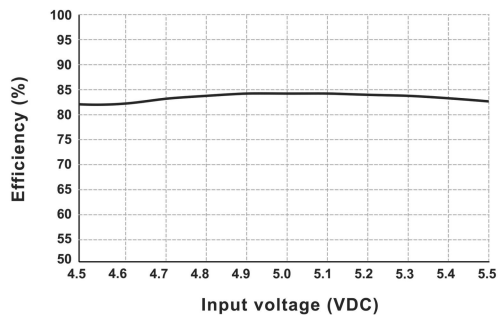

Efficiency VS Output Load (Vin=5V,DF1-05D05LS)

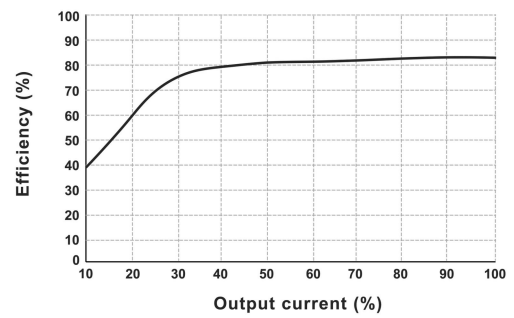

Design Reference - Application circuit

Application circuit

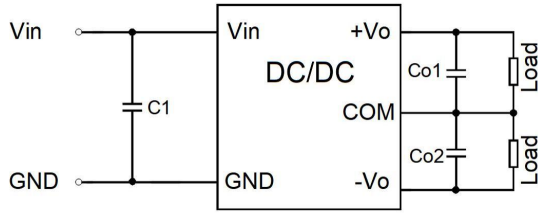

(Figure 1)

Recommended Capacitive Load Value Table

Vin	C1	Vo	Co1/Co2
3.3/5VDC	4.7uF/16V	3.3/5VDC	10μF/16V
12VDC	2.2uF/25V	9/12VDC	2.2μF/25V
15VDC	2.2uF/25V	15VDC	1.0μF/25V
24VDC	1.0uF/50V	24VDC	0.47μF/50V

All DC/DC converters in this series are tested according to the recommended application circuit (Figure 1) before the shipment. To further reduce input and output ripple, the external input and output capacitors C1/Co1/Co2 can be increased or capacitors with low equivalent series impedance can be selected. For each output, under safe and reliable operating conditions, the maximum capacitance of the filter capacitor must not exceed the maximum capacitive load of the product.

Design Reference - EMC Solutions - Recommended Circuits

EMC Recommended Circuit Design and Application

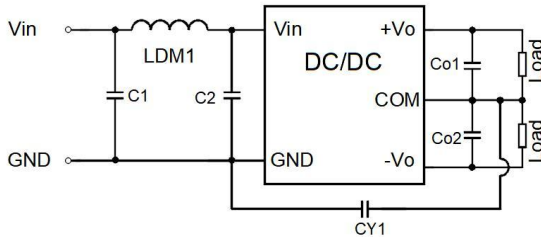

(Figure 2)

Recommended parameter values

C1	4.7μF /50V
C2	4.7μF /50V
Co1/Co2	Refer to Cout parameter in Figure 1
CY1	1000pF/4kV
LDM1	6.8μH

Note:

1. Typical Application

To further reduce input and output ripple, a Capacitance Filter network can be connected at the input and output terminals. The application circuit is shown in Figure 1. However, care should be taken to select an appropriate filter capacitor. If the capacitor is too large, it may cause startup issues. For each output, under conditions ensuring safe and reliable operation, the recommended capacitive load values are detailed in the table.

2. EMC Recommended Circuit: See Figure 2

3. Output Load Requirements

To ensure efficient and reliable operation of the module, the minimum output load during use must not be less than 10% of the rated load. If the required power is indeed small, please connect a resistor in parallel at the output (the sum of the resistor's power dissipation and the actual power used must be greater than or equal to 10% of the rated power).

Dimensions and Recommended Layout

DF1-xxDxxLS Dimensions and Recommended Layout

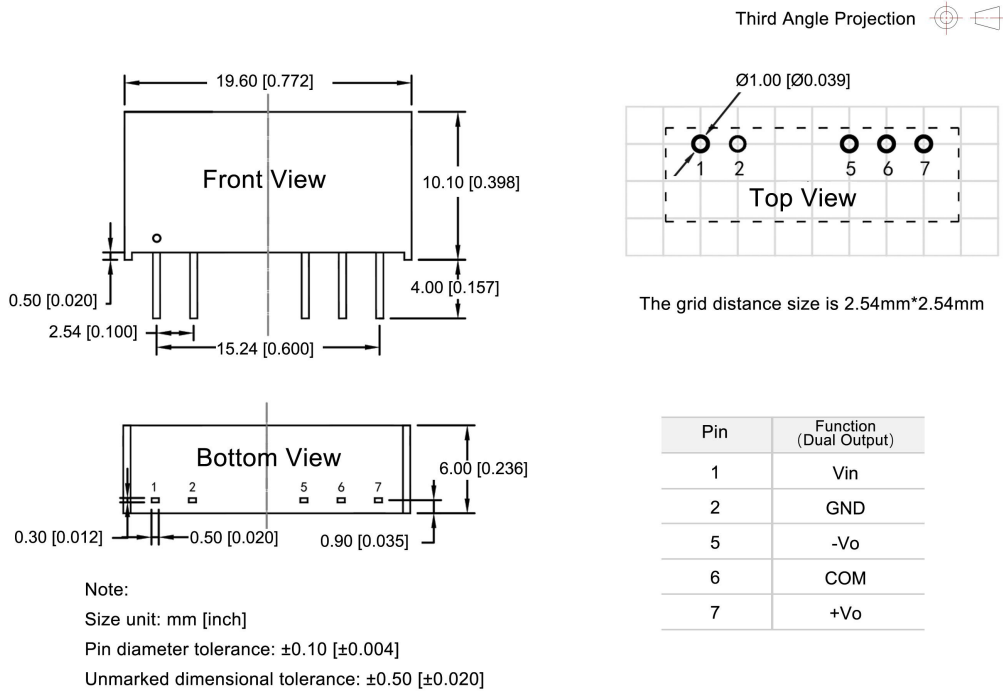

Packaging Information

Model series (Tube packaging)	Quantity per tube (pcs/ tube)	Quantity of electrostatic bag (pcs/ bag)	Quantity of inner box (pcs/ box)	Full box Quantity (pcs)
DF1-xxDxxLS	26	416	1664	6656

The schematic diagram of tube packaging is shown below:

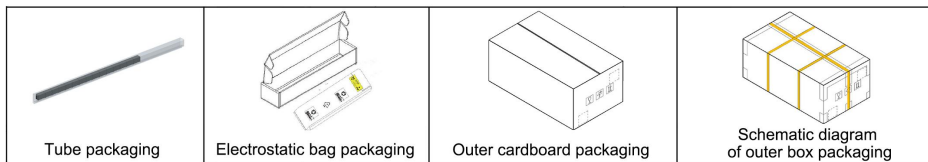

Product precautions

1. The input voltage should not exceed the specified range value, otherwise it may cause permanent and irreparable damage;
2. It is recommended to use at a load of over 5%. If the load is below 5%, the ripple index of the product may exceed the specifications, but it does not affect the reliability of the product;
3. The maximum capacitive load is tested within the input voltage range and under full load conditions;
4. Unless otherwise specified, all indicators in this manual are measured at $T_a=25\text{ }^\circ\text{C}$, humidity<75% RH, nominal input voltage, and output rated load;
5. All indicator testing methods in this manual are based on our company's corporate standards;
6. Our company can provide product customization, and specific requirements can be directly contacted by our technical personnel;
7. Product specifications are subject to change without prior notice.

Manufacturer contact information

Bettpower Guangzhou Electronic Technology Co., Ltd.

Website: www.bettpower.com

Telephone: +86 - 020 - 32166256

Email: info@bettpower.com

Address: Room 2514-2515, Building A1,1 Doutang Road, Huangpu District, Guangzhou, China

BETTPOWER is a registered trademark of BETTPOWER Guangzhou Electronic Technology Co., Ltd. All of its product names, models, trademarks and brands are the property of the Company.

BETTPOWER Guangzhou Electronic Technology Co., Ltd reserves all rights and the right of final interpretation.