

DH2-xxDxxLS Series

DC-DC Converter | 2W | SIP7 | Fixed voltage input, unregulated output | 6000VDC

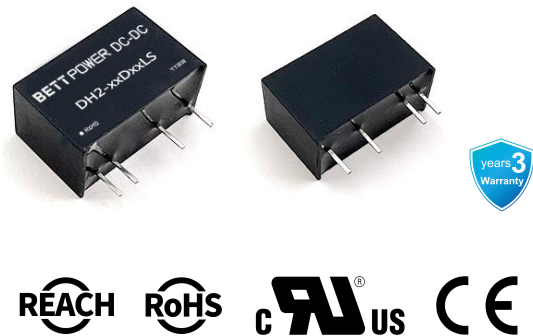

Features

- SIP7 Package
- Operating Temperature Range: -40°C ~ +105°C
- Isolation Voltage: 5000VAC/6000VDC
- Full Load Efficiency: up to 88% (typ.)
- Continuous Short Circuit Protection
- CMTI >200kV/μS
- Designed to meet IEC/EN/BS EN/UL 62368



Product Description



The DH2-xxDxxLS series is 2W unregulated DC/DC converters which features high isolation voltage of 5000VAC and 6000VDC and continuous short circuit protection. They are specially designed for applications where require compact size, high isolation, low isolation capacitor and low leakage current power. Typical applications are electricity, IGBT driver applications, etc.

Selection Guide

Certification	Part No.	Input Voltage	Output			Full Load Efficiency (%) Typ.	Capacitive Load (μF) Max.
		Nominal (Range) (VDC)	Voltage (VDC)	Current (mA) Min.	Current (mA) Max.		
EN/UL Pending	DH2-05D03LS	5(4.5~5.5)	±3.3	±20	±200	78	2200
	DH2-05D05LS	5(4.5~5.5)	±5	±20	±200	81	2200
	DH2-05D09LS	5(4.5~5.5)	±9	±11	±110	83	1000
	DH2-05D12LS	5(4.5~5.5)	±12	±9	±84	83	470
	DH2-05D15LS	5(4.5~5.5)	±15	±7	±68	83	470
	DH2-05D24LS	5(4.5~5.5)	±24	±5	±42	84	220
	DH2-12D03LS	12(10.8~13.2)	±3.3	±20	±200	79	1000
	DH2-12D05LS	12(10.8~13.2)	±5	±20	±200	82	1000
	DH2-12D09LS	12(10.8~13.2)	±9	±11	±110	83	680
	DH2-12D12LS	12(10.8~13.2)	±12	±9	±84	84	470
	DH2-12D15LS	12(10.8~13.2)	±15	±7	±68	84	470
	DH2-12D24LS	12(10.8~13.2)	±24	±5	±42	85	220
	DH2-15D03LS	15 (13.5~16.5)	±3.3	±20	±200	81	1000

Selection Guide

Certification	Part No.	Input Voltage	Output			Full Load Efficiency (%) Typ.	Capacitive Load(μF) Max.*
		Nominal(Range) (VDC)	Voltage (VDC)	Current (mA) Min.	Current (mA) Max.		
EN/UL Pending	DH2-15D05LS	15 (13.5~16.5)	±5	±20	±200	83	1000
	DH2-15D09LS	15 (13.5~16.5)	±9	±11	±110	85	680
	DH2-15D12LS	15 (13.5~16.5)	±12	±9	±84	85	470
	DH2-15D15LS	15 (13.5~16.5)	±15	±7	±68	85	470
	DH2-15D24LS	15 (13.5~16.5)	±24	±5	±42	86	220
	DH2-24D03LS	24 (21.6~26.4)	±3.3	±20	±200	81	1000
	DH2-24D05LS	24 (21.6~26.4)	±5	±20	±200	84	1000
	DH2-24D09LS	24 (21.6~26.4)	±9	±11	±110	85	680
	DH2-24D12LS	24 (21.6~26.4)	±12	±9	±84	86	470
	DH2-24D15LS	24 (21.6~26.4)	±15	±7	±68	86	470
	DH2-24D24LS	24 (21.6~26.4)	±24	±5	±42	88	220

Note:

- *The capacitive load of the two outputs for positive and negative output is the same.
- The above efficiency is measured at nominal input voltage and rated output load.

Input Specifications

Item	Operating Conditions		Min.	Typ.	Max.	Unit
Input Current (Full Load/No-load)	5VDC Input	3.3VDC Output	--	169/45	175/60	mA
		5VDC Output	--	246/45	253/60	mA
		Others	--	240/50	251/60	mA
	12VDC Input	3.3VDC Output	--	68/10	71/15	mA
		5/9VDC Output	--	100/10	104/15	mA
		Others	--	98/10	103/15	mA
	15VDC Input	3.3VDC Output	--	54/10	56/15	mA
		5/9VDC Output	--	79/10	83/15	mA
		Others	--	77/10	81/15	mA
	24VDC Input	3.3VDC Output	--	32/10	35/15	mA
		5/9VDC Output	--	48/10	52/15	mA
		Others	--	47/10	51/15	mA
Reflected Ripple Current			--	15	--	mA
Surge Voltage	5VDC Input		-0.7	--	9	VDC
	12VDC Input		-0.7	--	18	VDC
	15VDC Input		-0.7	--	21	VDC
	24VDC Input		-0.7	--	30	VDC
Input Filter Type	Capacitance Filter					
Hot Plug	Unavailable					

Output Specifications

Item	Operating Conditions		Min.	Typ.	Max.	Unit
Output Voltage Accuracy			See Output Regulation Curve			
Line Regulation	Input Voltage Variation Range $\pm 1\%$	3.3/5VDC Output	--	--	± 1.5	%
		Others	--	--	± 1.2	%
Load regulation	10%~100% Load	3.3/5VDC Output	--	--	20	%
		Others	--	--	15	%
Ripple & noise	20MHz Bandwidth (Peak-Peak)		--	80	150	mV
Temperature coefficient	Full Load		--	± 0.02	--	%/°C
Short circuit protection	Continuous, self-recovery					

Note: Ripple & noise are measured at 20MHz of bandwidth with a 10uF electrolytic capacitor and a 1uF ceramic capacitor connected in parallel at the output.

General Specifications

Item	Operating Conditions	Min.	Typ.	Max.	Unit
Isolation Voltage	Input-output, test time 1 minute, leakage current less than 1mA	5000	--	--	VAC

		6000	--	--	VDC
Insulation Resistance	Input-output, insulated voltage 500VDC	1000	--	--	MΩ
Isolation Capacitance	Input-Output,100KHz/0.1V	--	5	10	pF
Operating Temperature	Derating when operating temperature≥85℃ (See Temperature derating curve chart)	-40	--	105	℃
Storage Temperature		-55	--	125	℃
Case Temperature Rise	Ta=25℃, Nominal Input, Full Load	--	35	--	℃
Storage Humidity	Non-condensing	--	25	--	℃
Isolation Voltage	Input-output, test time 1 minute, leakage current less than 1mA	--	--	95	%RH
Soldering Profile	Wave soldering	260±5℃; Time: 5 - 10s			
	Manual soldering	360±10℃; Time: 3-5s			
Switching Frequency	Full load, nominal input voltage	--	220	--	kHz
MTBF	MIL-HDBK-217F@25℃	>3500Kh			

Mechanical Specifications

Case Material	Black flame-retardant heat-resistant plastic (UL94V-0)
Mechanical Dimensions	19.50 * 9.80* 12.50mm
Weight	4.1g (typ.)
Cooling Method	Free air convection

Electromagnetic Compatibility (EMC)

EMI	CE	CISPR32/EN55032 CLASS A (EMC recommended circuit see Fig. 2)			
	RE	CISPR32/EN55032 CLASS A (EMC recommended circuit see Fig. 2)			
EMS	ESD	IEC/EN61000-4-2	Contact ±8KV	perf. Criteria B	

Product Characteristic Curve

Temperature Derating Curve

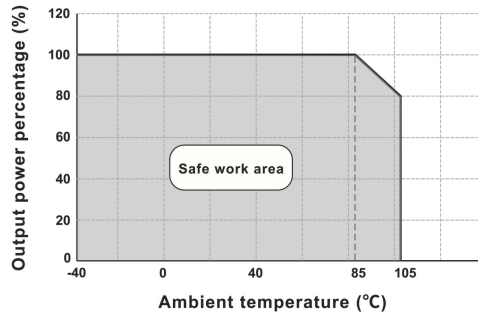

Output Regulation Curve (3.3V Output)

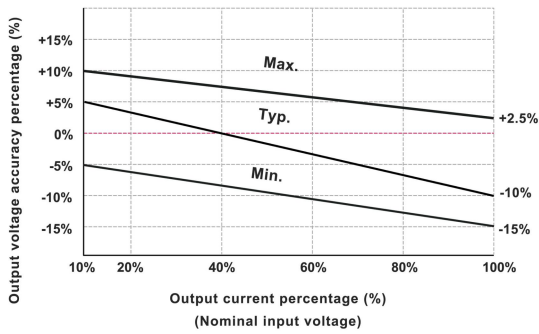

Output Regulation Curve (DH2-05D05LS, DH2-05D12LS, DH2-24D05LS, DH2-24D24LS)

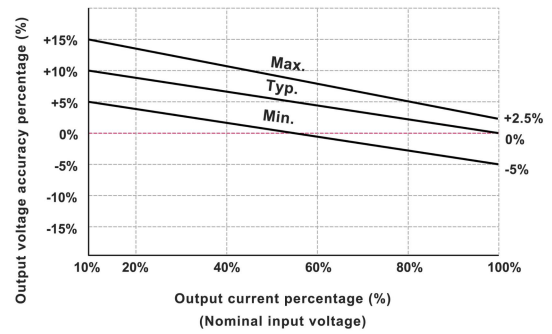

Output Regulation Curve (Others)

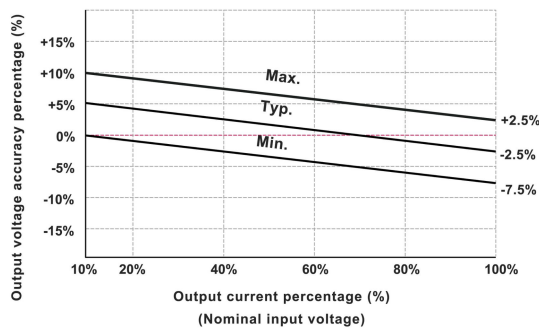

Design Reference - Application circuit

Application circuit

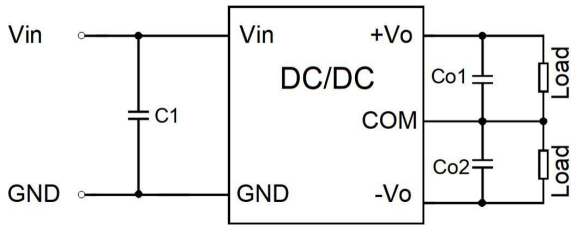

(Figure 1)

Recommended Capacitive Load Value Table

Vin	C1	Vo	Co1/Co2
5VDC	10uF/16V	3.3/5VDC	10uF/16V
12VDC	10uF/25V	9VDC	10uF/25V
15VDC	4.7uF/25V	12VDC	2.2uF/25V
24VDC	2.2uF/50V	15VDC	1uF/25V
		24VDC	0.47uF/50V

All DC/DC converters in this series are tested according to the recommended application circuit (Figure 1) before the shipment. To further reduce input and output ripple, increase the external input and output capacitors C_{in} and C_{out} , or select capacitors with lower equivalent series impedance. For each output, under safe and reliable operating conditions, the maximum capacitance of the filter capacitor must not exceed the product's maximum capacitive load.

Design Reference - EMC Solutions - Recommended Circuits

EMC Recommended Circuit Design and Application

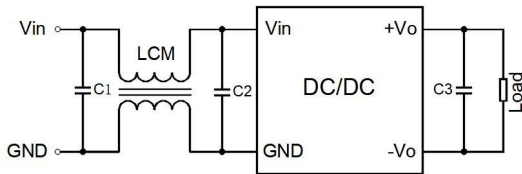

(Figure 2)

Recommended Parameter Table

C1	4.7μF /50V
C2	4.7μF /50V
C3	Refer to the C_{out} parameter in Figure 1
LCM	22μH

Note:

1. Typical Application

To further reduce input and output ripple, a Capacitance Filter network can be connected at the input and output terminals. The application circuit is shown in Figure 1. However, care should be taken to select an appropriate filter capacitor. If the capacitor is too large, it may cause startup issues. For each output, under conditions ensuring safe and reliable operation, the recommended capacitive load values are detailed in the table.

2. EMC Recommended Circuit: See Figure 2

3. Output Load Requirements

To ensure efficient and reliable operation of the module, the minimum output load during use must not be less than 10% of the rated load. If the required power is indeed very low, please connect a resistor in parallel at the output (the sum of the resistor's power dissipation and the actual usage power must be greater than or equal to 10% of the rated power).

Dimensions and Recommended Layout

DH2-xxDxxLS Dimensions and Recommended Layout

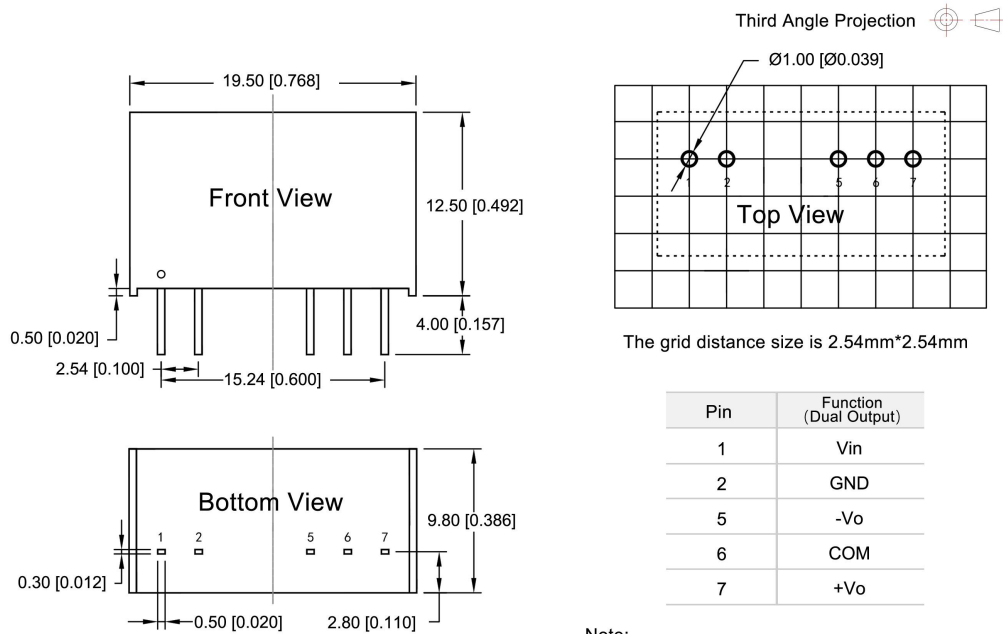

Note:
 Size unit: mm [inch]
 Pin diameter tolerance: ± 0.10 [± 0.004]
 Unmarked dimensional tolerance: ± 0.50 [± 0.020]

Packaging Information

Model series (Tube packaging)	Quantity per tube (pcs/ tube)	Quantity of electrostatic bag (pcs/ bag)	Quantity of inner box (pcs/ box)	Full box Quantity (pcs)
DH2-xxDxxLS	26	260	780	3120

The schematic diagram of tube packaging is shown below:

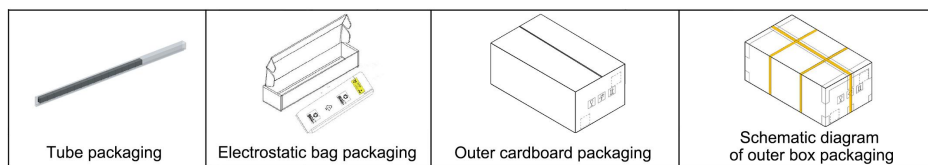

Product precautions

1. The input voltage should not exceed the specified range value, otherwise it may cause permanent and irreparable damage;
2. It is recommended to use at a load of over 5%. If the load is below 5%, the ripple index of the product may exceed the specifications, but it does not affect the reliability of the product;
3. The maximum capacitive load is tested within the input voltage range and under full load conditions;
4. Unless otherwise specified, all indicators in this manual are measured at $T_a=25\text{ }^\circ\text{C}$, humidity<75% RH, nominal input voltage, and output rated load;
5. All indicator testing methods in this manual are based on our company's corporate standards;
6. Our company can provide product customization, and specific requirements can be directly contacted by our technical personnel;
7. Product specifications are subject to change without prior notice.

Manufacturer contact information

Bettpower Guangzhou Electronic Technology Co., Ltd.

Website: www.bettpower.com

Telephone: +86 - 020 - 32166256

Email: info@bettpower.com

Address: Room 2514-2515, Building A1,1 Doutang Road, Huangpu District, Guangzhou, China

BETTPOWER is a registered trademark of BETTPOWER Guangzhou Electronic Technology Co., Ltd. All of its product names, models, trademarks and brands are the property of the Company.

BETTPOWER Guangzhou Electronic Technology Co., Ltd reserves all rights and the right of final interpretation.